



Designation: D5405/D5405M – 98 (Reapproved 2021)

Standard Test Method for Conducting Time-to-Failure (Creep-Rupture) Tests of Joints Fabricated from Nonbituminous Organic Roof Membrane Material¹

This standard is issued under the fixed designation D5405/D5405M; the number immediately following the designation indicates the year of original adoption or, in the case of revision, the year of last revision. A number in parentheses indicates the year of last approval. A superscript epsilon (ϵ) indicates an editorial change since the last revision or reapproval.

1. Scope

1.1 This test method covers laboratory determination of the time-to-failure (creep-rupture) of joints fabricated from nonbituminous organic roof membrane material. The test method covers both T-peel and lap-shear joints subjected to constant tensile load under controlled environmental conditions. The joints, made from either unreinforced or fabric-reinforced membrane material, are prepared in the laboratory or sampled from roofs in service.

1.2 Sheet materials from which the joints are fabricated include vulcanized rubbers, nonvulcanized polymeric sheets, and thermoplastics. The bonding methods for joint formation include the use of liquid-based adhesives, preformed tapes, and thermal and solvent weld processes.

1.3 The values stated in either SI units or inch-pound units are to be regarded separately as standard. The values stated in each system may not be exact equivalents; therefore, each system shall be used independently of the other. Combining values from the two systems may result in nonconformance with the standard.

1.4 *This standard does not purport to address all of the safety concerns, if any, associated with its use. It is the responsibility of the user of this standard to establish appropriate safety, health, and environmental practices and determine the applicability of regulatory limitations prior to use.*

1.5 *This international standard was developed in accordance with internationally recognized principles on standardization established in the Decision on Principles for the Development of International Standards, Guides and Recommendations issued by the World Trade Organization Technical Barriers to Trade (TBT) Committee.*

¹ This test method is under the jurisdiction of ASTM Committee D08 on Roofing and Waterproofing and is the direct responsibility of Subcommittee D08.18 on Nonbituminous Organic Roof Coverings.

Current edition approved Dec. 1, 2021. Published December 2021. Originally approved in 1993. Last previous edition approved in 2015 as D5405/D5405M – 98 (2015). DOI: 10.1520/D5405_D5405M-98R21.

2. Referenced Documents

- 2.1 *ASTM Standards*:²
 - D816 Test Methods for Rubber Cements
 - D907 Terminology of Adhesives
 - D1079 Terminology Relating to Roofing and Waterproofing
 - D1876 Test Method for Peel Resistance of Adhesives (T-Peel Test)

3. Terminology

3.1 *Definitions*—For definitions of terms used in this test method, refer to Terminologies D907 and D1079.

3.2 *Definitions of Terms Specific to This Standard*:

3.2.1 *creep-rupture test*—a test that measures the time-to-failure of a specimen subjected to a constant load; progressive specimen deformation may also be measured.

3.2.2 *failure*—rupture of the bond resulting in complete separation of its adherends under the test conditions; or, alternatively, rupture of the membrane material away from the bonded section of the test specimen (that is, material rupture).

3.2.3 *time-to-failure*—the period of time beginning when a joint specimen is placed under load and ending when failure occurs.

4. Summary of Test Method

4.1 This test method is a creep-rupture test without measurement of specimen deformation. The time-to-failure, in hours, of joints fabricated from nonbituminous organic roof membrane materials is measured when subjected to constant deadweight loads under controlled temperature and humidity conditions.

5. Significance and Use

5.1 An important factor affecting the performance of joints of nonbituminous membranes is their ability to remain bonded over the membrane's expected service life. Time-to-failure

² For referenced ASTM standards, visit the ASTM website, www.astm.org, or contact ASTM Customer Service at service@astm.org. For *Annual Book of ASTM Standards* volume information, refer to the standard's Document Summary page on the ASTM website.

tests provide a means of characterizing the behavior of joints under constant load over time.

5.2 Creep is a sensitive index of rheological properties that depend on material, load, temperature, and time. Time-to-failure data that are obtained over a relatively short time period can evaluate one factor affecting a joint's ability to withstand static loading over a relatively long time period.

5.3 Time-to-failure data for joints of nonbituminous organic roof membrane specimens can be used for the following: (1) to provide a measure of the load-carrying ability of the joint as a function of time at various levels of load, temperature, and relative humidity; (2) to characterize the joint with regard to factors affecting performance, such as surface preparation of the adherend, solvent-based adhesive thickness and open time, environment during adhesive application and cure, and temperature of thermal welding processes; and (3) to compare the effects of different bonding processes or adhesive bonding materials on joint performance.

5.4 While it is considered that the results obtained by this laboratory test may afford a measure of the performance of seams in service, provided that load, temperature, and humidity conditions are known, no direct correlation has been established.

6. Apparatus

6.1 Test Chamber, of sufficient size to hold a minimum of 15 specimens. The height of the chamber shall be sufficient to allow suspension of the deadweight loads and specimen deformation during testing. The chamber shall be structurally capable of supporting the loads anticipated during testing without appreciable deflection.

NOTE 1—A minimum height of 600 mm [24 in.] is suitable for the specimen sizes described in this test method if they are not extremely extensible. A taller chamber may be needed if they are extremely extensible.

6.1.1 Temperature and Humidity Control—The control of temperature and humidity is important, since small changes in these variables may produce large changes in time-to-failure. The temperature and relative humidity within the chamber shall be controlled within ±3 °C [± 5 °F] and ±5 % relative humidity, respectively, over the duration of the test. Any deviations from these limits shall be given in the test report. The selected temperature and humidity conditions shall be uniform throughout the enclosed space (±3 °C or ±5 °F and ±5 % relative humidity). If this uniformity is achieved through mechanical air circulation, it shall not cause the specimens to sway, vibrate, or be otherwise disturbed.

NOTE 2—Suggested test conditions are as follows: (1) normal ambient temperature (approximately 23 °C or 73 °F) and humidity (50 % relative humidity); and (2) extremes to which the seams may be subjected in service.

6.2 Specimen and Load Clamping—The chamber shall be equipped with a means for clamping the joint specimens vertically to the top of the interior of the chamber, or other suitable upper support. Also, a clamp shall be provided to secure the deadweight loads to the bottom of the joint

specimens. Figs. 1 and 2 show a suggested clamping arrangement including the deadweight load.

6.3 Deadweight Loads, of appropriate mass (see Section 10).

NOTE 3—It is convenient to have available a means of providing variable loads that may differ from test to test, depending on the properties of the joint specimens and test conditions. Hollow pipe nipples containing lead shot and sealed with end caps provide convenient deadweights. The mass of the deadweights is adjusted by adding or removing lead shot.

6.4 Load Application Mechanism—This device allows for placing all of the joint specimens under load simultaneously. An example of such a device is a large tray, suspended on pulleys, which supports the loads attached to the bottom of the specimens. Lowering the tray allows all test specimens and deadweights attached to them to be suspended freely at once.

NOTE 4—If each specimen has its own timer device (see 6.5), it is not necessary to load all specimens simultaneously.

6.5 Timer Device, for recording the total time over which each individual specimen is under load, or for marking the time at which failure of each specimen occurs. The sensitivity of the timer shall be as follows:

Failure Time	Timer Sensitivity
≤25 h	0.1 min
>25 and ≤100 h	0.01 h
>100 h	0.1 h

NOTE 5—For investigations involving multiple specimens in the chamber, a computer-controlled timer that records the time-to-failure has been found to be satisfactory. In this case, a micro-electrical circuit connected to the computer is set up for each specimen. The circuit consists of a wire loop, of which one segment is a short length of wire (trigger wire) attached to each grip on the test specimen and set to stop the computer clock when failure occurs. At the point of attachment at the top grip, the trigger wire is inserted in an electrical connector. When the specimen fails and the deadweight on the lower grip falls, the trigger wire is pulled from the connector, breaking the circuit and stopping the clock.

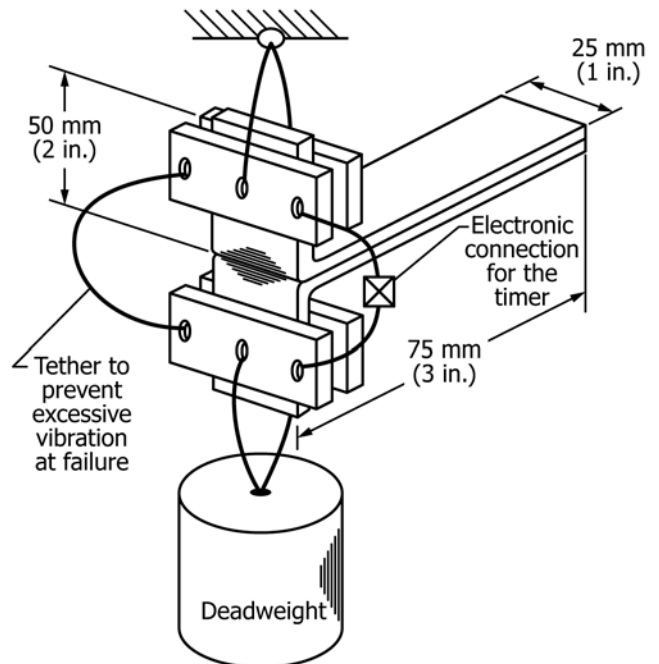

FIG. 1 Schematic of a T-Peel Specimen Clamped Under Load